

**User's Manual
(maintenance)**

GARUDAN[®]

**GPS/E-1006
series**



ANITA B, s.r.o.

Průmyslová 2453/7

680 01 Boskovice

Czech Republic

tel: +420 516 454 774

+420 516 453 496

fax: +420 516 452 751

e-mail: info@anita.cz

www.garudan.cz

IMPORTANT SAFETY INSTRUCTIONS

1. Observe the basic safety measures, including, but not limited to the following ones, whenever you use the machine.
2. Read all the instructions, including, but not limited to this Instruction Manual before you use the machine. In addition, keep this Instruction Manual so that you may read it at anytime when necessary.
3. Use the machine after it has been ascertained that it conforms with safety rules/standards valid in your country.
4. All safety devices must be in position when the machine is ready for work or in operation. The operation without the specified safety devices is not allowed.
5. This machine shall be operated by appropriately-trained operators.
6. For your personal protection, we recommend that you wear safety glasses.
7. For the following, turn off the power switch or disconnect the power plug of the machine from the receptacle.
 - 7-1 For threading needle(s), looper, spreader etc. and replacing bobbin.
 - 7-2 For replacing part(s) of needle, presser foot, throat plate, looper, spreader, feed dog, needle guard, folder, cloth guide etc.
 - 7-3 For repair work.
 - 7-4 When leaving the working place or when the working place is unattended.
 - 7-5 When using clutch motors without applying brake, it has to be waited until the motor stopped totally.
8. If you should allow oil, grease, etc. used with the machine and devices to come in contact with your eyes or skin or swallow any of such liquid by mistake, immediately wash the contacted areas and consult a medical doctor.

9. Tampering with the live parts and devices, regardless of whether the machine is powered, is prohibited.
10. Repair, remodeling and adjustment works must only be done by appropriately trained technicians or specially skilled personnel.
11. General maintenance and inspection works have to be done by appropriately trained personnel.
12. Repair and maintenance works of electrical components shall be conducted by qualified electric technicians or under the audit and guidance of specially skilled personnel.
Whenever you find a failure of any of electrical components, immediately stop the machine.
13. Before making repair and maintenance works on the machine equipped with pneumatic parts such as an air cylinder, the air compressor has to be detached from the machine and the compressed air supply has to be cut off. Existing residual air pressure after disconnecting the air compressor from the machine has to be expelled. Exceptions to this are only adjustments and performance checks done by appropriately trained technicians or specially skilled personnel.
14. Periodically clean the machine throughout the period of use.

15. Grounding the machine is always necessary for the normal operation of the machine. The machine has to be operated in an environment that is free from strong noise sources such as high-frequency welder.
16. An appropriate power plug has to be attached to the machine by electric technicians. Power plug has to be connected to a grounded receptacle.

17. The machine is only allowed to be used for the purpose intended. Other used are not allowed.
18. Remodel or modify the machine in accordance with the safety rules/standards while taking all the effective safety measures. SEWQ assumes no responsibility for damage caused by remodeling or modification of the machine.

19. Warning hints are marked with the two shown symbols.





Danger of injury to operator or service staff



Items requiring special attention

FOR SAFE OPERATION OF GPS/E-1006

	<ol style="list-style-type: none">1. To avoid electrical shock hazards, neither open the cover of the electrical box for the motor nor touch the components mounted inside the electrical box.2. After changing the pattern, make sure the needle entry point. If the pattern is protruded from the work clamp feet, the needle will interfere with the work clamp feet during sewing, and it is dangerous due to the needle breakage or the like.
	<ol style="list-style-type: none">1. So as to prevent possible accidents caused by abrupt start of the sewing machine, depress the start switch after ascertaining that there is no interfering thing under the needle when winding the bobbin thread.2. So as to prevent possible accidents caused by abrupt start of the sewing machine, never place your fingers under the feeding frame since the feeding frame automatically comes down when the pattern is changed, the needle threading switch is ON, the bobbin thread winding switch is ON or the feeding frame switch is ON. During operation, be careful not to allow your fingers to come close to the feeding frame.

Contents

I. CONFIGURATION	6
1. NAMES OF MAIN UNIT	6
II. OPERATION OF THE SEWING MACHINE	7
1. LUBRICATION	7
2. ATTACHING THE NEEDLE	7
3. THREADING THE MACHINE HEAD	8
4. INSTALLING AND REMOVING THE BOBBIN CASE	9
5. INSTALLING THE BOBBIN	9
6. ADJUSTING THE THREAD TENSION	10
7. ADJUSTING THE THREAD TAKE-UP SPRING	10
8. ADJUSTING THE HEIGHT OF THE INTERMEDIATE PRESSER	11
III.MAINTENANCE	12
1. ADJUSTING THE HEIGHT OF THE NEEDLE BAR	13
2. ADJUSTING THE NEEDLE-TO SHUTTLE RELATION	13
3. THE MOVING KNIFE AND COUNTER KNIFE	14
4. CLEANING THE FILTER	14
5. DRAINING WASTE OIL	14
IV.OTHERS	15
1. TROUBLES AND CORRECTIVE MEASURES	15

I. CONFIGURATION
1. NAMES OF MAIN UNIT

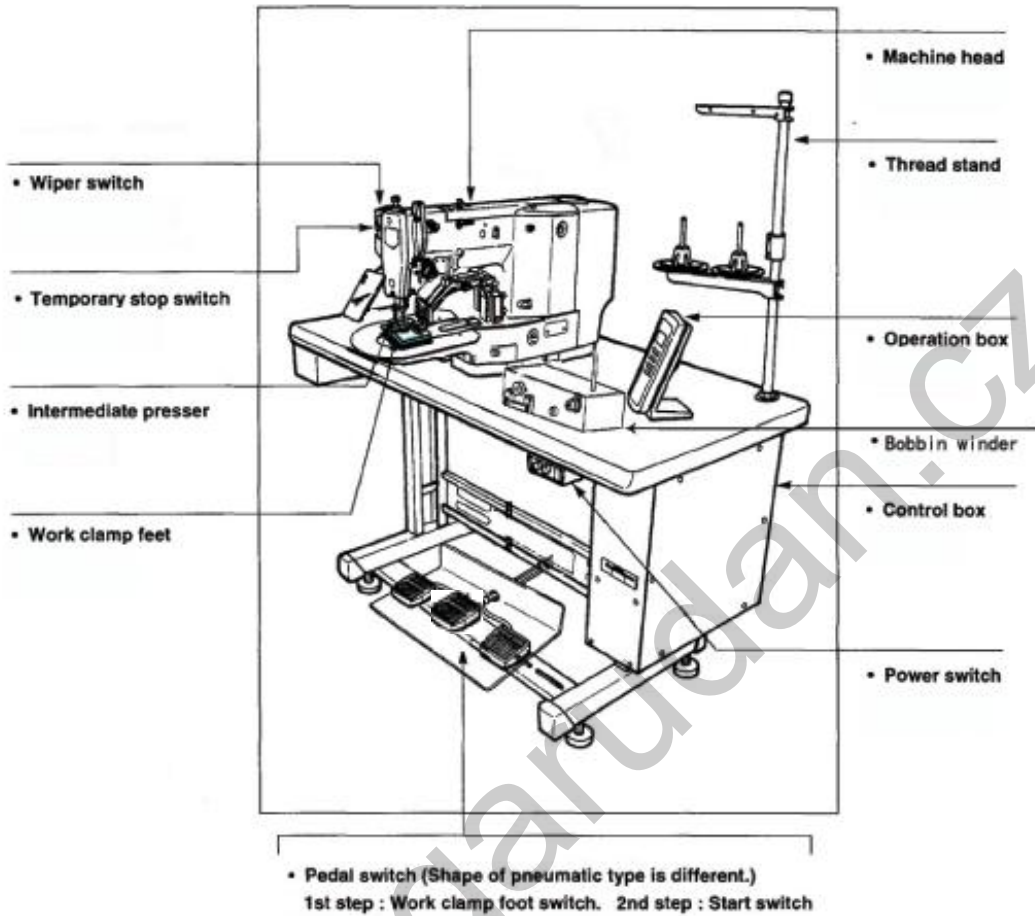

Air regulator

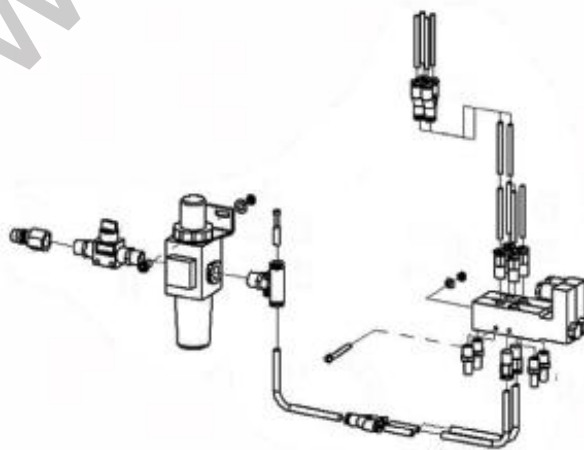

II. OPERATION OF THE SEWING MACHINE

1. LUBRICATION



WARNING :

Turn OFF the power before starting the work so as to prevent accidents caused by abrupt start of the sewing machine.

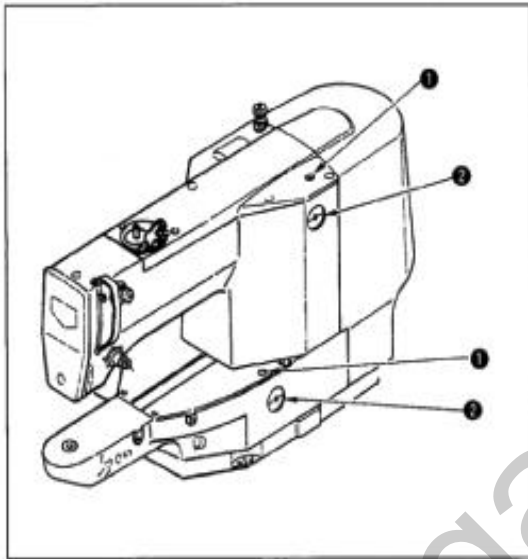

- 1) Once a day, fill oil from oil hole ❶ on the machine head up to the red mark in the center of oil gauge ❷.

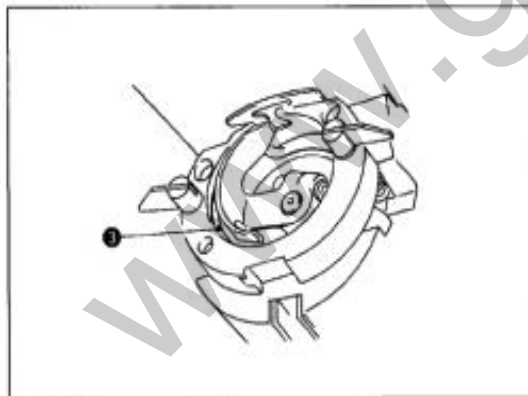

- 2) Apply one drop of oil to hook race ❸ part to spread on it.

2. ATTACHING THE NEEDLE



WARNING :

Turn OFF the power before starting the work so as to prevent accidents caused by abrupt start of the sewing machine.

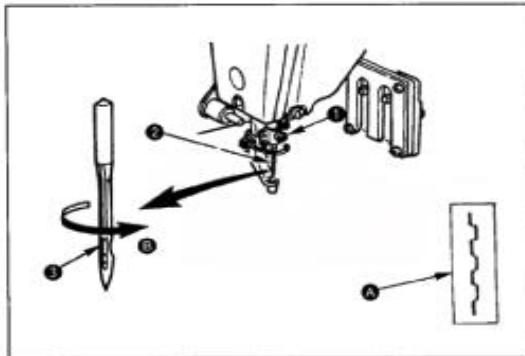

Loosen setscrew ❶ and hold needle ❷ with the long groove facing toward you. Then fully insert it into the hole in the needle bar, and tighten setscrew ❶.

(Caution)

If the stitches are made as shown in A, attach the needle facing to the direction B to a small extent.

3. THREADING THE MACHINE HEAD



WARNING :

Do not place your fingers or any thing under the presser since there is a danger of damage of your fingers or hands caused by being caught in the presser, needle, etc.

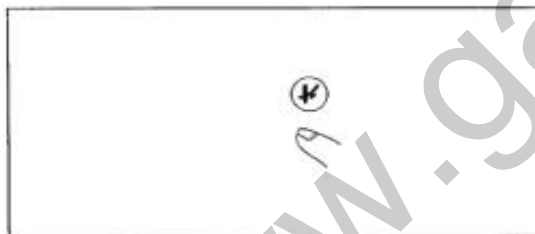

When passing thread through the needle, perform following operation to lower the intermediate presser and the feeding frame.

- 1) Press the ⚡ key on the operation box.
- 2) After passing thread through the needle, press again the ⚡ key and the intermediate presser and the feeding frame go up.

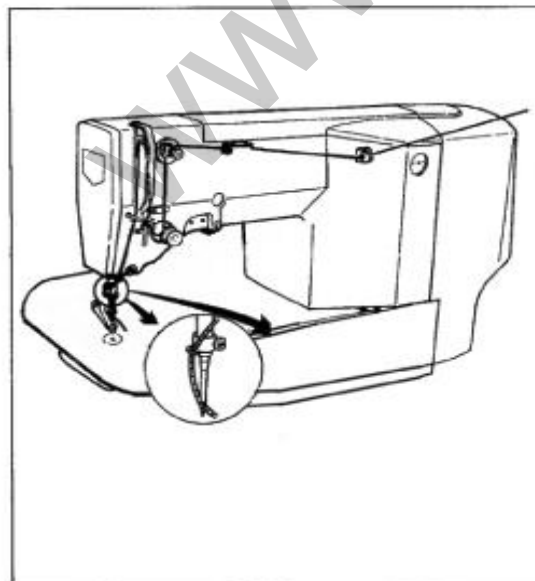

Pull out the thread by approximately 4 cm from the needle after threading through the needle.

4. INSTALLING AND REMOVING THE BOBBIN CASE



WARNING :

Turn OFF the power before starting the work so as to prevent accidents caused by abrupt start of the sewing machine.

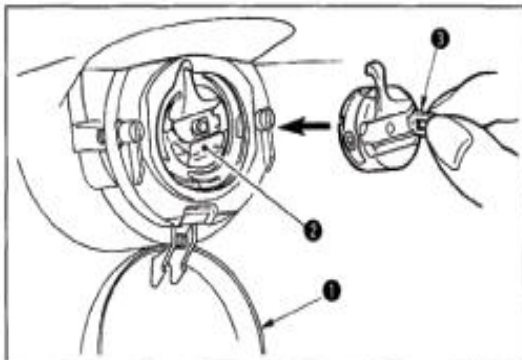

- 1) Open hook cover ❶.
- 2) Raise latch ❷ of bobbin case ❸, and remove the bobbin case.
- 3) When installing the bobbin case, fully insert it into the shuttle shaft, and close the latch.

(Caution) If it is not fully inserted, bobbin case ❸ may slip off during sewing.

5. INSTALLING THE BOBBIN

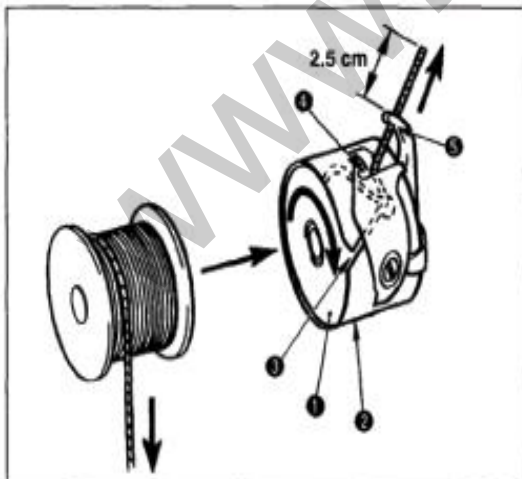

- 1) Set the bobbin ❶ into bobbin case ❷ in the direction shown in the figure.
- 2) Pass the thread through thread slit ❸ of bobbin case ❷, and pull the thread as it is. By so doing, the thread will pass under the tension spring and be pulled out from thread hole ❹.
- 3) Pass the thread through thread hole ❺ of the horn section, and pull out the thread by 2.5 cm from the thread hole.

(Caution) If the bobbin is installed in the bobbin case orienting the reverse direction, the bobbin thread pulling out will result in an inconsistent state.

6. ADJUSTING THE THREAD TENSION

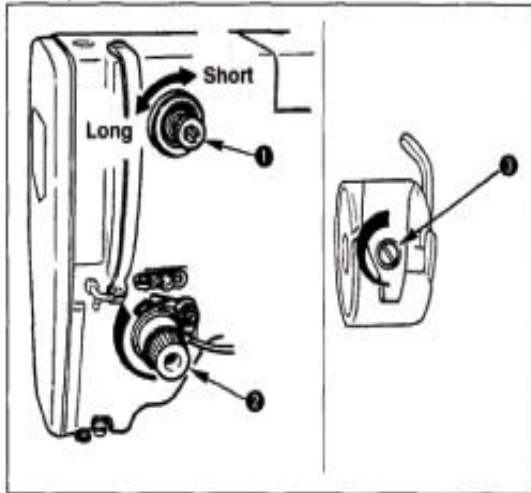

If thread tension controller No. 1 **①** is turned clockwise, the length of remaining thread on the needle after thread trimming will be shorter. If it is turned counterclockwise, the length will be longer.

Shorten the length to an extent that the thread is not slipped off.

Adjust the needle thread tension with **②**, and bobbin thread tension with **③**.

7. ADJUSTING THE THREAD TAKE-UP SPRING

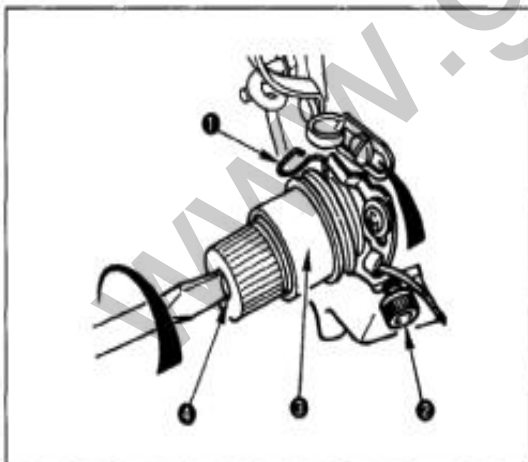

The standard stroke of thread take-up spring **①** is 6 to 8 mm, and the pressure at the start is 0.3 to 0.5N.

- 1) Adjusting the stroke
Loosen setscrew **②**, and turn thread tension asm. **③**.
- 2) Adjusting the pressure
Insert a screwdriver into the slit of thread tension rod **④**, and turn it.
- 3) When the stroke of thread take-up spring is changed, adjust the thread breakage detector plate referring to

8. ADJUSTING THE HEIGHT OF THE INTERMEDIATE PRESSER/

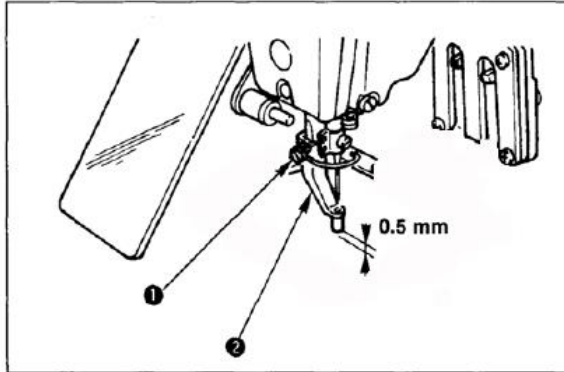

- 1) Lower the intermediate presser ②. (Refer to “3. Threading the machine head”.)
- 2) Turn the handwheel to lower the intermediate presser ② to its lowest position.
When the intermediate presser ② is in the lowest position of its stroke, adjust so that the clearance between the intermediate presser and the cloth is approximately 0.5 mm.
- 3) Loosen setscrew ① and adjust the height of intermediate presser ②.

III. MAINTENANCE

1. ADJUSTING THE HEIGHT OF THE NEEDLE BAR



WARNING :

Turn OFF the power before starting the work so as to prevent accidents caused by abrupt start of the sewing machine.

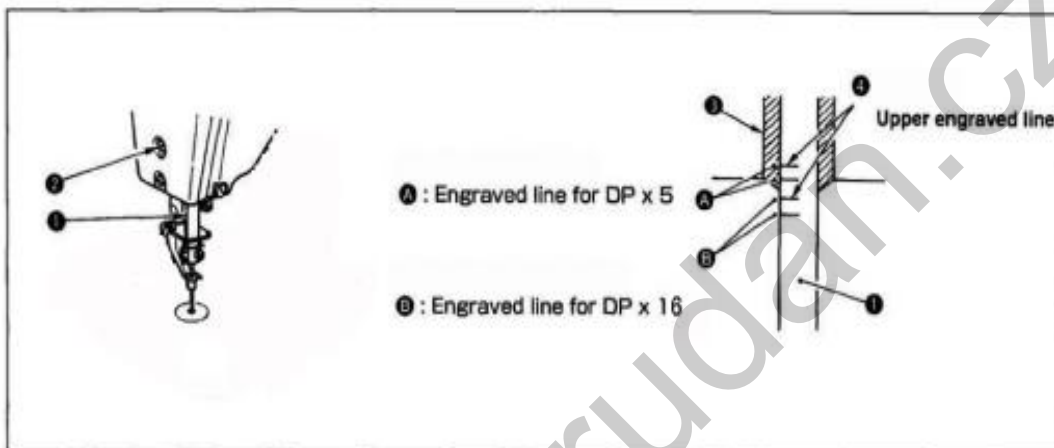

Bring needle bar ① to the lowest position of its stroke. Loosen needle bar connection screw ② and adjust so that upper marker line ④ engraved on the needle bar aligns with the bottom end of needle bar bushing, lower ③.

(Caution) After the adjustment, make sure that there is no uneven torque.

※ When stitch skipping occurs in accordance with the sewing conditions, adjust the height of the needle bar so as to lower it by 0.5 to 1 mm from the needle bar engraved line ④.

2. ADJUSTING THE NEEDLE-TO-SHUTTLE RELATION



WARNING :

Turn OFF the power before starting the work so as to prevent accidents caused by abrupt start of the sewing machine.

Relation between needle and engraved lines

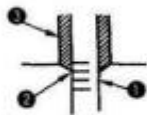

When DPx5 is used.

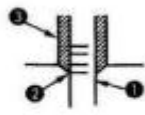

When DPx16 is used.

- 1) Turn the handwheel by hand. When needle bar ① has gone up, adjust so that lower marker line ② engraved on the needle bar aligns with the bottom end of the needle bar bushing ③, lower.

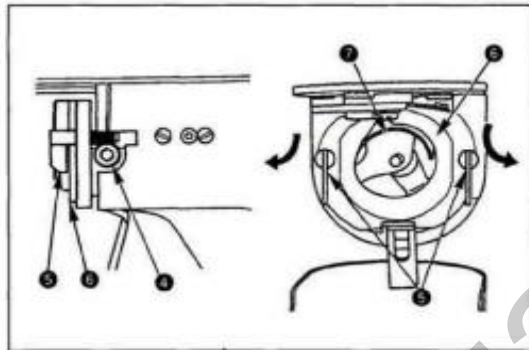

- 2) Loosen setscrew ④ in the driver. Open inner hook pressers ⑤ to the right and left, and remove inner hook presser ⑥.

(Caution)

At this time, be careful not to let inner hook ⑦ come off and fall.

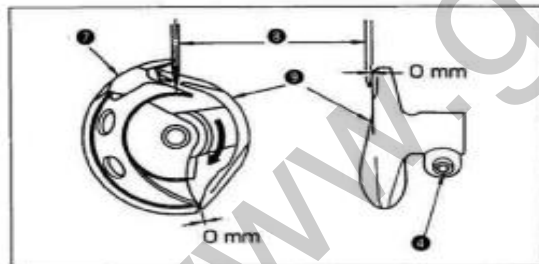

- 3) Adjust so that the point of shuttle ⑦ meets the center of needle ⑧, and that a clearance of 0 mm is provided between the front end face of driver ⑨ and needle as the front end face of driver receives needle to prevent the needle from being bent. Then tighten setscrew ④.

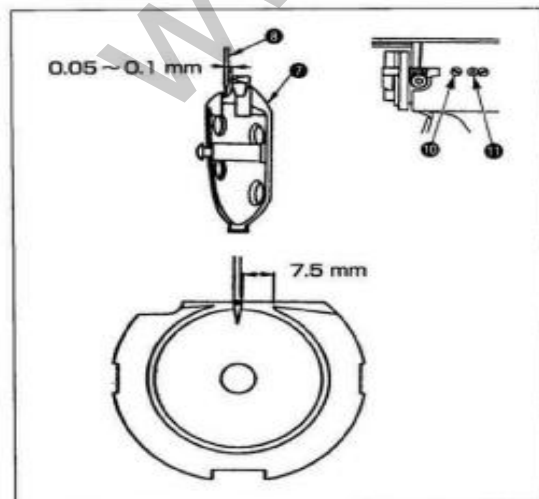

- 4) Loosen shuttle race screw ⑩, and adjust the longitudinal position of the shuttle race. To do this adjustment, turn shuttle race adjusting shaft ⑪ clockwise or counterclockwise to provide a 0.05 to 0.1 mm clearance between needle ⑧ and the blade point of shuttle ⑦.
- 5) After adjusting the longitudinal position of shuttle race, further adjust to provide a 7.5 mm clearance between the needle and the shuttle race. Then, tighten screw ⑩ of shuttle race.

3. THE MOVING KNIFE AND COUNTER KNIFE



WARNING :
Turn OFF the power before starting the work so as to prevent accidents caused by abrupt start of the sewing machine.

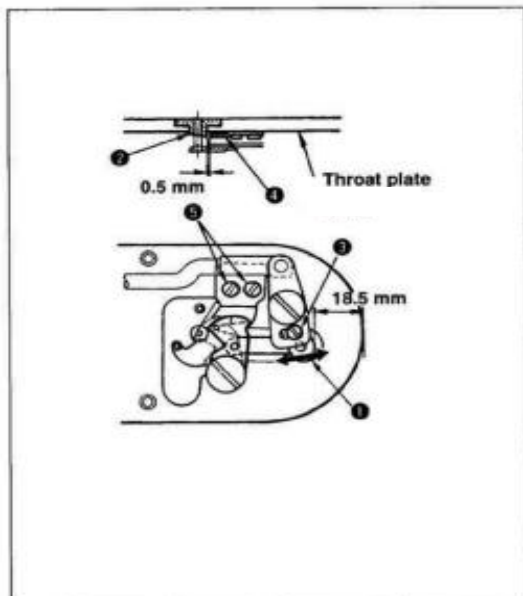

- 1) Loosen adjusting screw ⑤ so that a clearance of 18.5 mm is provided between the front end of the throat plate and the top end of thread trimmer lever, small ①. To adjust, move the moving knife in the direction of arrow.
- 2) Loosen setscrew ⑥ so that a clearance of 0.5 mm is provided between needle hole guide ② and counter knife ④. To adjust, move the counter knife.

4. CLEANING THE FILTER



WARNING :
Turn OFF the power before starting the work so as to prevent accidents caused by abrupt start of the sewing machine.

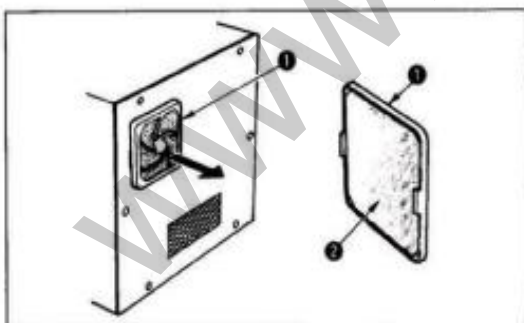

Clean the filter ② of the control box fan once every week.

- 1) Pull the screen kit ① in the direction of the arrow to remove it.
- 2) Wash the filter ② under running water.
- 3) Reinstall the filter and the screen kit ①.

5. DRAINING WASTE OIL

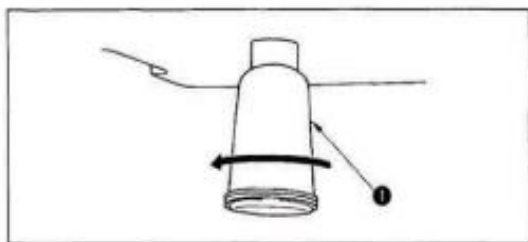

When polyethylene oiler ① becomes filled with oil, remove it and drain the oil.

IV. OTHERS

1. TROUBLES AND CORRECTIVE MEASURES (SEWING CONDITIONS)

Trouble	Cause	Corrective measures
1. The needle thread slips off at the start of bar-tacking.	<ol style="list-style-type: none"> ① Stitches are slipped at the start. ② The needle thread remaining on the needle after thread trimming is too short. ③ The bobbin thread is too short. 	<ul style="list-style-type: none"> ○ Adjust the clearance between the needle and the shuttle to 0.05 to 0.1 mm. ○ Set soft-start sewing at the start of bartacking. ○ Correct the thread tension release timing of the thread tension controller No. 2. ○ Increase the tension of the thread take-up spring, or decrease the tension of the thread tension controller No. 1. ○ Decrease the tension of the bobbin thread. ○ Increase the clearance between the needle hole guide and the counter knife.
2. Thread often breaks or synthetic fiber thread splits finely.	<ol style="list-style-type: none"> ① The shuttle or the driver has scratches. ② The needle hole guide has scratches. ③ Fibrous dust is in the groove of the shuttle race. ④ The needle thread tension is too high. ⑤ The tension of the thread take-up spring is too high. ⑥ The synthetic fiber thread melts due to heat generated on the needle. 	<ul style="list-style-type: none"> ○ Take it out and remove the scratches using a fine whetstone or buff. ○ Buff or replace it. ○ Take out the shuttle and remove the fibrous dust from the shuttle race. ○ Reduce the needle thread tension. ○ Reduce the tension. ○ Use silicone oil.
3. The needle often breaks.	<ol style="list-style-type: none"> ① The needle is bent. ② The needle is too thin for the material. ③ The driver excessively bends the needle. ④ Feed timing is excessively slow. 	<ul style="list-style-type: none"> ○ Replace the bent needle. ○ Replace it with a thicker needle according to the material. ○ Correctly position the needle and the shuttle. ○ Make the feeding timing fast.
4. Treads are not trimmed.	<ol style="list-style-type: none"> ① The counter knife is dull. ② The difference in level between the needle hole guide and the counter knife is not enough. ③ The moving knife has been improperly positioned. ④ The last stitch is skipped. 	<ul style="list-style-type: none"> ○ Replace the counter knife. ○ Increase the bend of the counter knife. ○ Correct the position of the moving knife. ○ Correct the timing between the needle and the shuttle.
5. Stitch skipping often occurs.	<ol style="list-style-type: none"> ① The motions of the needle and shuttle are not properly synchronized. ② The clearance between the needle and shuttle is too large. ③ The needle is bent. ④ The driver excessively bends the needle. 	<ul style="list-style-type: none"> ○ Correct the positions of the needle and shuttle. ○ Correct the positions of the needle and shuttle. ○ Replace the bent needle. ○ Correctly position the driver.
6. The needle thread comes out on the wrong side of the material.	<ol style="list-style-type: none"> ① The needle thread tension is not high enough. ② The needle thread after thread trimming is too long. 	<ul style="list-style-type: none"> ○ Increase the needle thread tension. ○ Make the feed timing slow. ○ Increase the tension of the thread tension controller No. 1.
7. Threads break at time of thread trimming.	<ol style="list-style-type: none"> ① The moving knife has been improperly positioned. 	<ul style="list-style-type: none"> ○ Correct the position of the moving knife.
8. When synthetic fiber thread is used, at the start or end of sewing, needle thread rises or remaining of needle thread is excessive.	<ol style="list-style-type: none"> ① In case of synthetic fiber thread, the thread is harder than other threads and penetration resistance to material is small. 	<ul style="list-style-type: none"> ○ When making a pattern, set the sewing pitch at the start and end of sewing to 1 mm or less.

www.garudan.cz